

# PVC inspection chamber

**Material:** PVC (polyvinylchloride)

**Certification:** Naar NBN EN 13598-1 with BENOR certification

**Execution:** With straight flow profile. In and outlets are provided with a wafix socket. All glued connection are executed with SABA S3 glue.

Company:

Projet:

Date:

	Ø Chamber	d max.	A min.	H Standard	B	P	Weight
	D mm	mm	mm	mm	mm	mm	kg
□	250	160	110	410	50	60	3
□	315	200	110	410	40	70	6
□	400	250	140	500	60	80	9

Section over flow direction

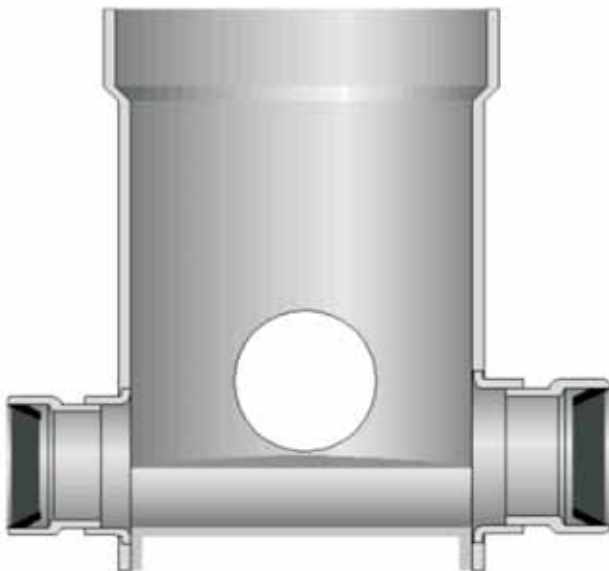

Section perpendicular to flow direction

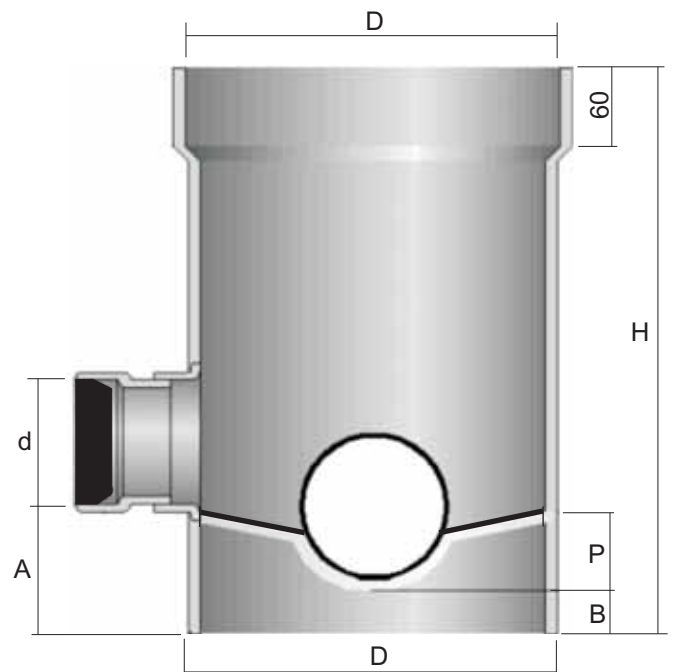

**Description:** Inspection chamber with straight flow profile. The chamber is provided with a collar to increase the height of the chamber to the wanted level, this can be done by glueing a piece of standard pvc tube in to the collar. The height of the chamber H is a standard height but the chambers can also be executed according to plan. Additional connection are possible at various heights and angles.